

# 5-Phase stepping motor

## Ordering information

<b>A</b> □	<b>8K</b> -	<b>M</b> <b>5</b> <b>6</b> <b>4</b> □	□	□
				Wire connection (*)
				Motor shaft
				Motor length(mm)
				Flange width(mm)
				Rating current[A]/Phase
				Stopping torque
				Motor type
				Series

□	Pentagon wiring
S	Standard wiring
□	Single shaft
W	Dual shaft

2	24mm	3	30.5
		5	46.5
4	42mm	3	33
		4	39
		5	47
6	60mm	4	48.5
		6	59.5
		9	89
9	85mm	6	68
		9	98
		13	128

Motor phase	
S	0.75
M	1.4
G	2.8

kgf • cm	
□	Standard Shaft
H	Hollow shaft type
G	Gear type

\*Standard connection is optional.  
 \*See M-30 Page for Geared type.

## Specifications

Type	Model	Max. excitation stop torque (kgf • cm)	Rated current (A/phase)	Winding resistance(Ω)	Rotor inertia (g • cm <sup>2</sup> )	Motor length (mm)	Weight (kg)	
<b>24 Square</b>	Standard shaft type	<b>02K-S523(W)</b>	0.18	0.75	1.1	30.5	0.07	
		<b>04K-S525(W)</b>	0.28	0.75	1.7	46.5	0.12	
<b>42 Square</b>	Standard shaft type	<b>A1K-S543(W)</b> - □	1.3	0.75	1.7	35	0.25	
		<b>A2K-S544(W)</b> - □	1.8	0.75	2.2	54	0.3	
		<b>A3K-S545(W)</b> - □	2.4	0.75	2.2	68	0.4	
	Hollow shaft type	<b>AH1K-S543</b>	1.3	0.75	1.7	35	0.25	
		<b>AH2K-S544</b>	1.8	0.75	2.2	54	0.3	
		<b>AH3K-S545</b>	2.4	0.75	2.2	68	0.4	
<b>60 Square</b>	Standard shaft type	<b>A4K-S564(W)</b> - □	4.2	0.75	2.6	175	48.5	0.6
		<b>A4K-M564(W)</b> - □	4.2	1.4	0.8	175	48.5	0.6
		<b>A8K-S566(W)</b> - □	8.3	0.75	4.0	280	59.5	0.8
		<b>A8K-M566(W)</b> - □	8.3	1.4	1.1	280	59.5	0.8
		<b>A16K-M569(W)</b> - □	16.6	1.4	1.8	560	89	1.3
		<b>A16K-G569(W)</b> - □	16.6	2.8	0.56	560	89	1.3
	Hollow shaft type	<b>AH4K-S564(W)</b>	4.2	0.75	2.6	175	48.5	0.6
		<b>AH4K-M564(W)</b>	4.2	1.4	0.8	175	48.5	0.6
		<b>AH8K-S566(W)</b>	8.3	0.75	4.0	280	59.5	0.8
		<b>AH8K-M566(W)</b>	8.3	1.4	1.1	280	59.5	0.8
		<b>AH16K-M569(W)</b>	16.6	1.4	1.8	560	89	1.3
		<b>AH16K-G569(W)</b>	16.6	2.8	0.56	560	89	1.3
<b>85 Square</b>	Standard shaft type	<b>A21K-M596(W)</b> - □	21	1.4	1.76	1400	68	1.7
		<b>A21K-G596(W)</b> - □	21	2.8	0.4	1400	68	1.7
		<b>A41K-M599(W)</b> - □	41	1.4	2.60	2700	98	2.8
		<b>A41K-G599(W)</b> - □	41	2.8	0.58	2700	98	2.8
		<b>A63K-M5913(W)</b> - □	63	1.4	3.92	4000	128	3.8
		<b>A63K-G5913(W)</b> - □	63	2.8	0.86	4000	128	3.8
	Hollow shaft type	<b>AH21K-M596(W)</b>	21	1.4	1.76	1400	68	1.7
		<b>AH21K-G596(W)</b>	21	2.8	0.4	1400	68	1.7
		<b>AH41K-M599(W)</b>	41	1.4	2.60	2700	98	2.8
		<b>AH41K-G599(W)</b>	41	2.8	0.58	2700	98	2.8
		<b>AH63K-M5913(W)</b>	63	1.4	3.92	4000	128	3.8
		<b>AH63K-G5913(W)</b>	63	2.8	0.86	4000	128	3.8

\*Motor length is without shaft.  
 \* ( ) indicates dual shaft of motor.  
 \*S type for hollow shaft type is optional. (Except for 24mm)

# AK/AHK SERIES

## ■ Specifications

### ●24 Square / 42 Square

Model	02K-S523□	04K-S525□	A1K-S543□-□ AH1K-S543	A2K-S544□-□ AH2K-S544	A3K-S545□-□ AH3K-S545
Max. holding torque	0.18[kgf·cm]	0.28[kgf·cm]	1.3[kgf·cm]	1.8[kgf·cm]	2.4[kgf·cm]
	0.018[N·m]	0.028[N·m]	0.13[N·m]	0.18[N·m]	0.24[N·m]
Rotor moment of inertia	4.2[g·cm <sup>2</sup> ]	8.2[g·cm <sup>2</sup> ]	35[g·cm <sup>2</sup> ]	54[g·cm <sup>2</sup> ]	68[g·cm <sup>2</sup> ]
	4.2×10 <sup>-7</sup> [kg·m <sup>2</sup> ]	8.2×10 <sup>-7</sup> [kg·m <sup>2</sup> ]	35×10 <sup>-7</sup> [kg·m <sup>2</sup> ]	54×10 <sup>-7</sup> [kg·m <sup>2</sup> ]	68×10 <sup>-7</sup> [kg·m <sup>2</sup> ]
Rated current	0.75A/Phase				
Basic square	0.72° / 0.36° (Full/Half)				
Insulation class	CLASS B type(130°C)				
Insulation resistance	Max. 100MΩ (Standard 500VDC mega) between motor coil-case				
Dielectric strength	1Min. at 1kVAC 50/60Hz between motor coil-case				
Ambient temperature	-10°C ~ +50°C, Storage condition : -25°C ~ +85°C				
Ambient humidity	35 ~ 85%RH				
Protection	IP30(IEC34-5)				
Weight	0.07kg	0.12kg	0.25kg	0.3kg	0.4kg

### ●60 Square

Model	A4K-S564□-□ AH4K-S564□	A4K-M564□-□ AH4K-M564□	A8K-S566□-□ AH8K-S566□	A8K-M566□-□ AH8K-M566□	A16K-M569□-□ AH16K-M569□	A16K-G569□-□ AH16K-G569□
Max. holding torque	4.2[kgf·cm]		8.3[kgf·cm]		16.6[kgf·cm]	
	0.42[N·m]		0.83[N·m]		1.66[N·m]	
Rotor moment of inertia	175[g·cm <sup>2</sup> ]		280[g·cm <sup>2</sup> ]		560[g·cm <sup>2</sup> ]	
	175×10 <sup>-7</sup> [kg·m <sup>2</sup> ]		280×10 <sup>-7</sup> [kg·m <sup>2</sup> ]		560×10 <sup>-7</sup> [kg·m <sup>2</sup> ]	
Rated current	0.75A/Phase	1.4A/Phase	0.75A/Phase	1.4A/Phase	1.4A/Phase	2.8A/Phase
Basic square	0.72° / 0.36° (Full/Half)					
Insulation class	CLASS B type(130°C)					
Insulation resistance	Max. 100MΩ (Standard 500VDC mega) between motor coil-case					
Dielectric strength	1Min. at 1kVAC 50/60Hz between motor coil-case					
Ambient temperature	-10°C ~ +50°C, Storage condition : -25°C ~ +85°C					
Protection	35 ~ 85%RH					
Ambient humidity	IP30(IEC34-5)					
Weight	0.6kg		0.8kg		1.3kg	

### ●85 Square

Model	A21K-M596□-□ AH21K-M596□	A21K-G596□-□ AH21K-G596□	A41K-M599□-□ AH41K-M599□	A41K-G599□-□ AH41K-G599□	A63K-M5913□-□ AH63K-M5913□	A63K-G5913□-□ AH63K-G5913□
Max. holding torque	21[kgf·cm]		41[kgf·cm]		63[kgf·cm]	
	2.1[N·m]		4.1[N·m]		6.3[N·m]	
Rotor moment of inertia	1400[g·cm <sup>2</sup> ]		2700[g·cm <sup>2</sup> ]		4000[g·cm <sup>2</sup> ]	
	1400×10 <sup>-7</sup> [kg·m <sup>2</sup> ]		2700×10 <sup>-7</sup> [kg·m <sup>2</sup> ]		4000×10 <sup>-7</sup> [kg·m <sup>2</sup> ]	
Rated current	1.4A/Phase	2.8A/Phase	1.4A/Phase	2.8A/Phase	1.4A/Phase	2.8A/Phase
Basic square	0.72° / 0.36° (Full/Half)					
Insulation class	CLASS B type(130°C)					
Insulation resistance	Max. 100MΩ (Standard 500VDC mega) between motor coil-case					
Dielectric strength	1Min. at 1kVAC 50/60Hz between motor coil-case					
Ambient temperature	-10°C ~ +50°C, Storage condition : -25°C ~ +85°C					
Protection	35 ~ 85%RH					
Ambient humidity	IP30(IEC34-5)					
Weight	1.7kg		2.8kg		3.8kg	

(A) Counter

(B) Timer

(C) Temp. controller

(D) Power controller

(E) Panel meter

(F) Tacho/Speed/Pulse meter

(G) Display unit

(H) Sensor controller

(I) Proximity sensor

(J) Photo electric sensor

(K) Pressure sensor

(L) Rotary encoder

(M) 5-Phase stepping motor &amp; Driver &amp; Controller

# 5-Phase stepping motor

## □24mm/□42mm/□60mm/□85mm 0.72° 5-Phase Stepping Motor

### ■ Features

- Compact design and light weight with high accuracy, speed and torque.
- Best suited for small-sized equipment applications regardless of installation environment owing to its compact design.
- Available to select the standard and high speed type.

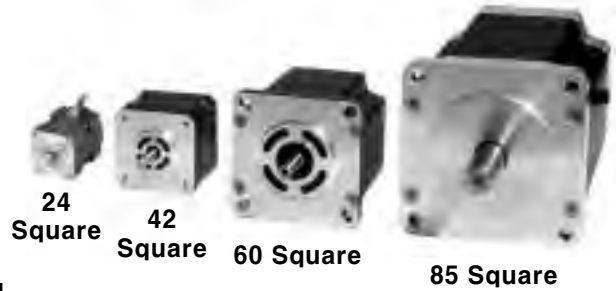

**⚠ Please read "Caution for your safety" in operation manual before using.**



### ■ Dimensions

#### ●02K-S523(W)

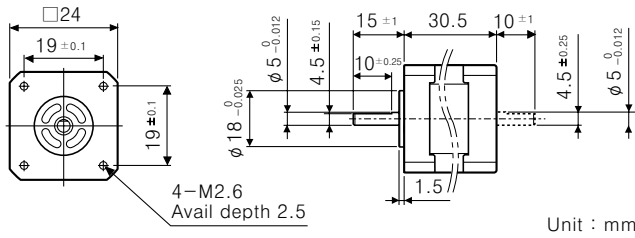

#### ●04K-S525(W)

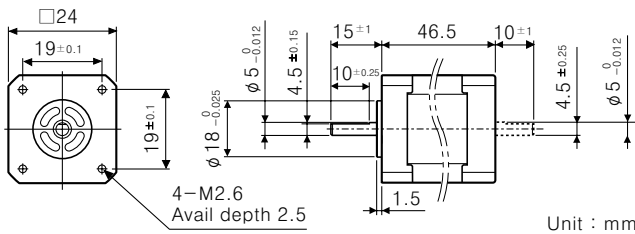

#### ●A1K-S543(W)-□

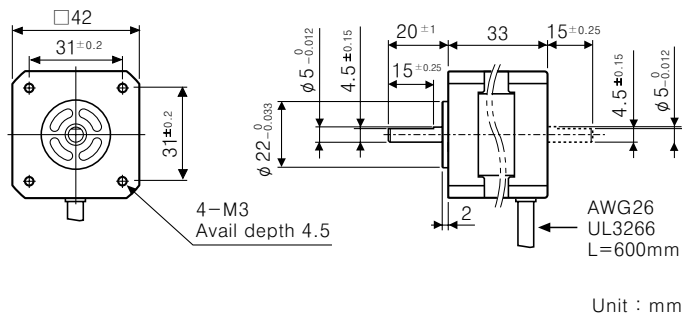

### ■ Characteristic

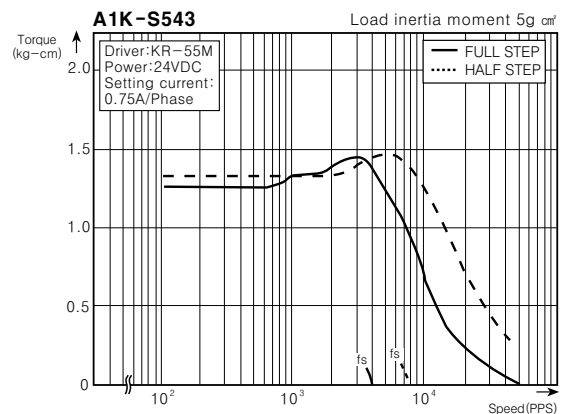
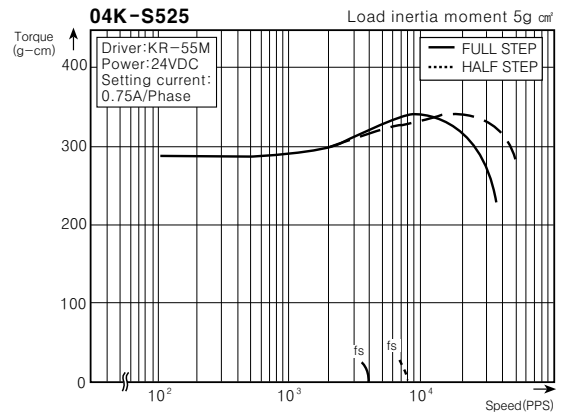
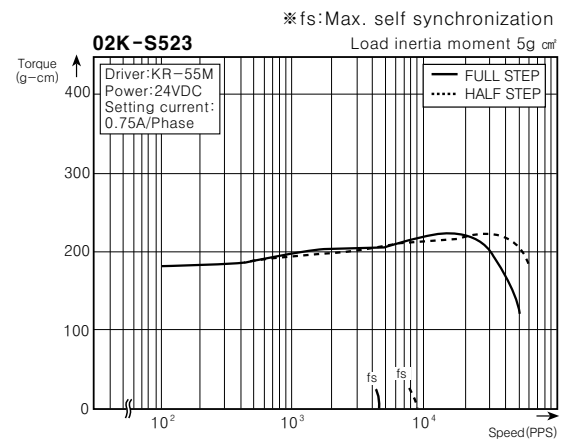

※This is dual shaft dimension. In case of single shaft there is no(.....) shaft.

## ■ Dimensions

### ● A2K-S544(W)-□

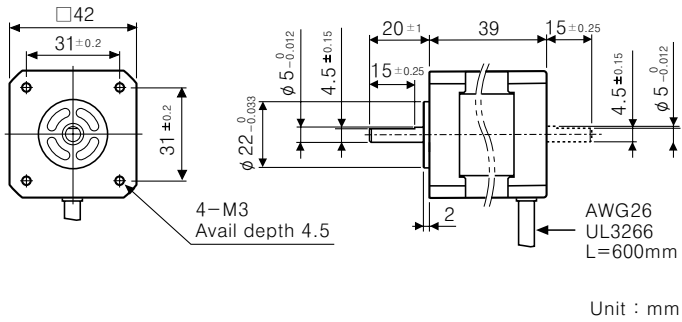

### ● A3K-S545(W)-□

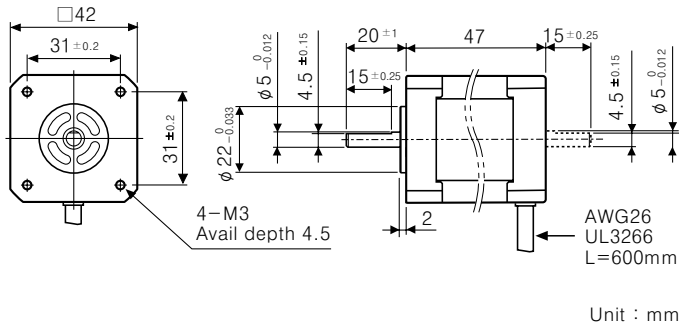

### ● A4K-□564(W)-□

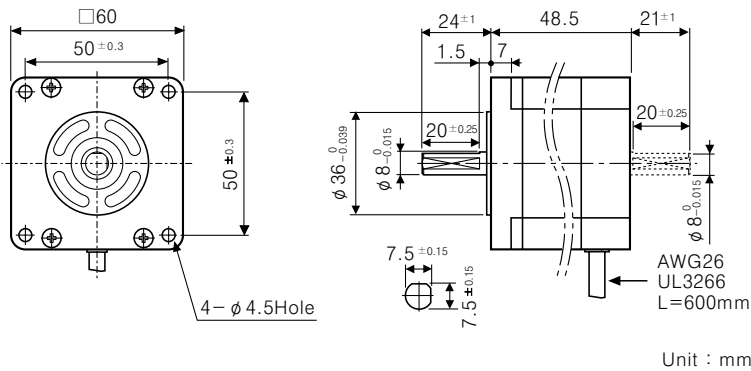

### ● A8K-□566(W)-□

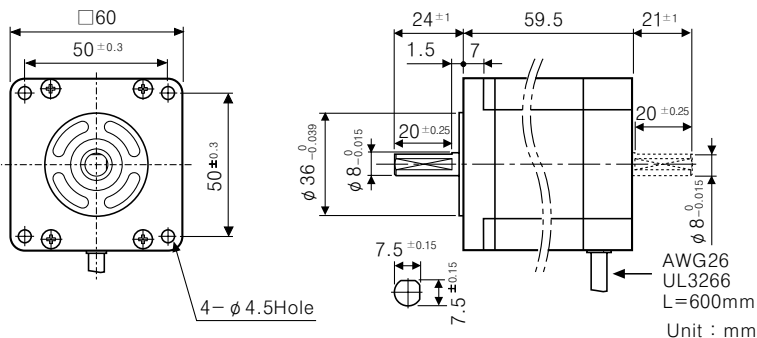

## ■ Characteristic

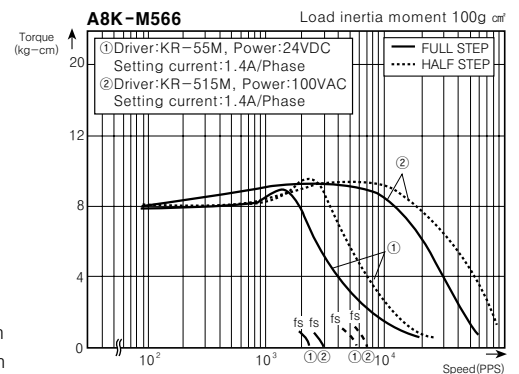
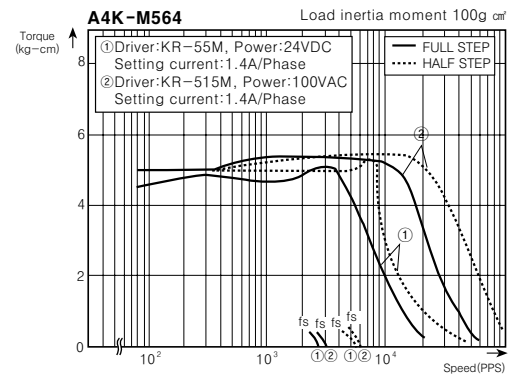
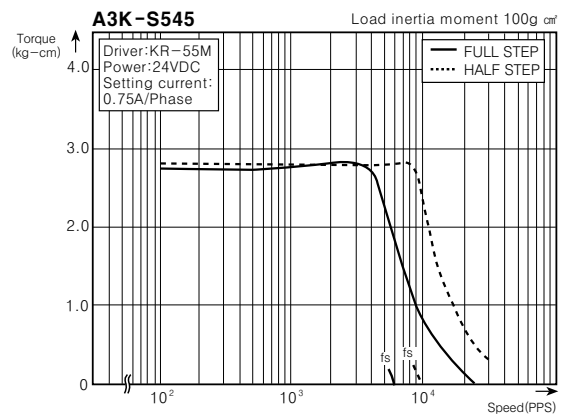
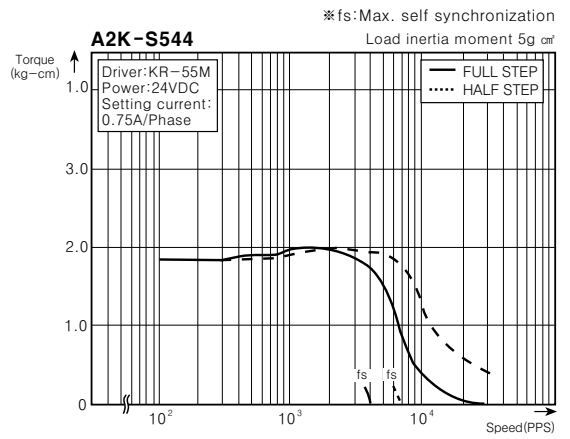

※ This is dual shaft dimension. In case of single shaft there is no (.....) shaft.

(A) Counter

(B) Timer

(C) Temp. controller

(D) Power controller

(E) Panel meter

(F) Tacho/Speed/Pulse meter

(G) Display unit

(H) Sensor controller

(I) Proximity sensor

(J) Photo electric sensor

(K) Pressure sensor

(L) Rotary encoder

(M) 5-Phase stepping motor & Driver & Controller

# 5-Phase stepping motor

## ■ Dimensions

### ● A16K-□569(W)-□

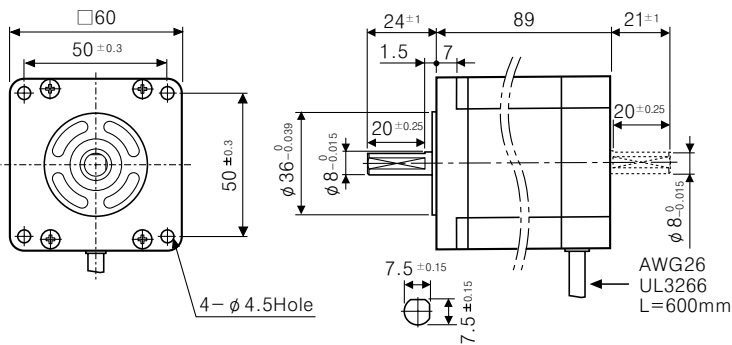

Unit : mm

## ■ Characteristic

※ fs:Max. self synchronization  
Load inertia moment 100g cm<sup>2</sup>

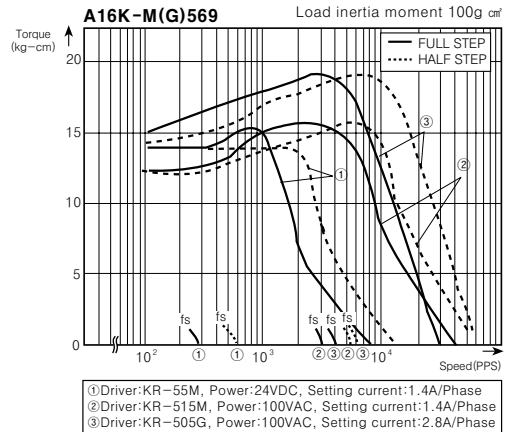

### ● A21K-□596(W)-□

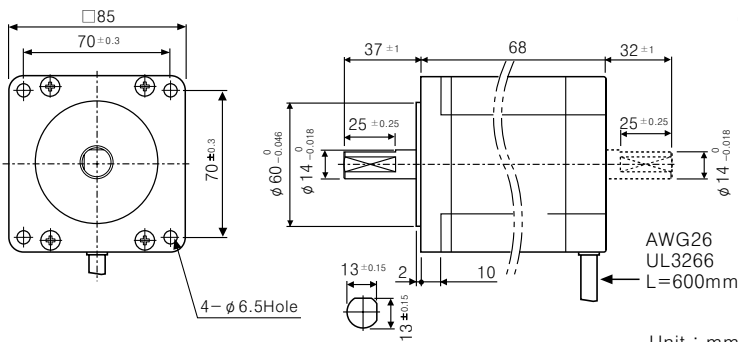

Unit : mm

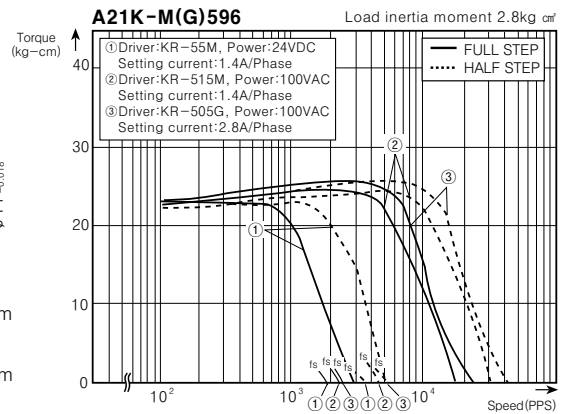

### ● A41K-□599(W)-□

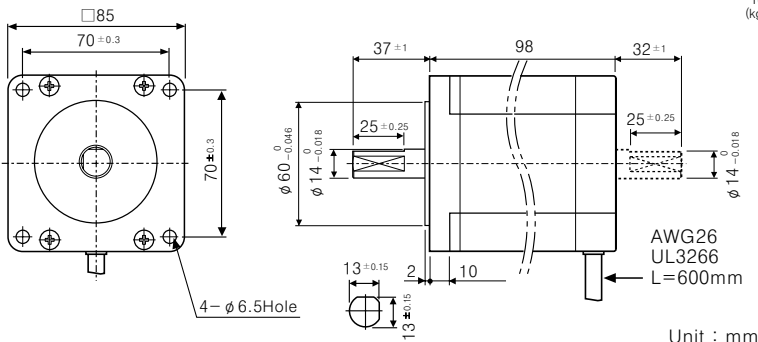

Unit : mm

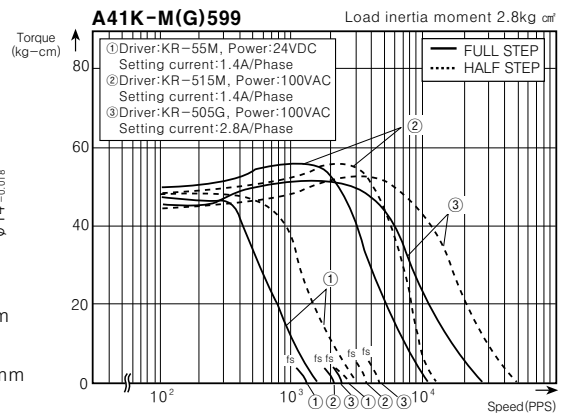

### ● A63K-□5913(W)-□

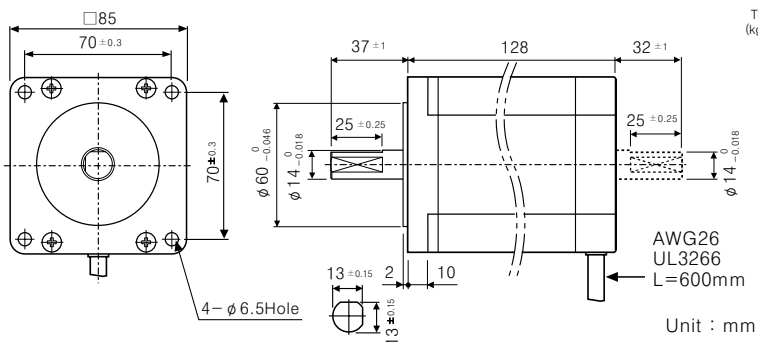

Unit : mm

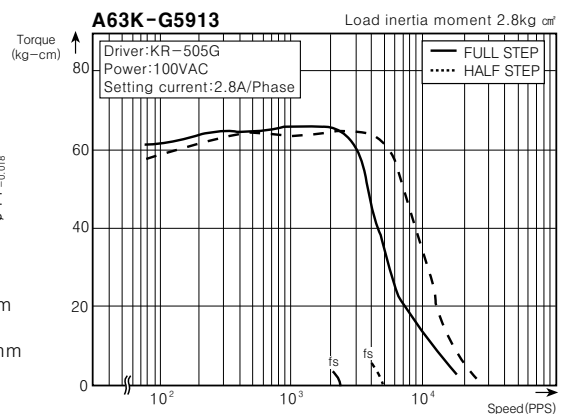

※ This is dual shaft dimension. In case of single shaft there is no( ..... ) shaft.

## ■ Connection diagram

Each phase (Coil) of stepping motor and color of lead wire is shown as following.  
Our product has Pentagon and Standard connections by inner connection of motor.

### ● Pentagon connection

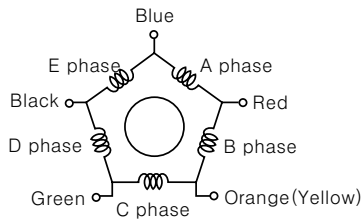

### ● Standard connection

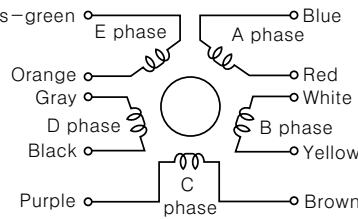

## ■ Motor mounting

### 1. Set mounting

- ① Please mount closely on the surface of a panel which has high-thermal conductivity such as iron, aluminum etc. for protection against heat and vibration.
- ② Please assemble motor tightly using hexagon wrench bolt.
- ③ Please see below chart for the thickness of mounting plate and bolt.

#### ● 24 Square/42 Square

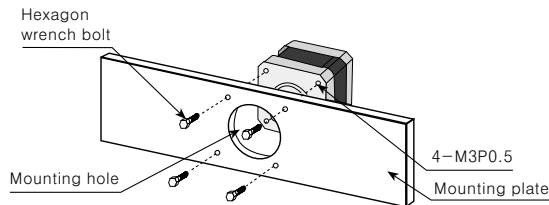

#### ● 60 Square/85 Square

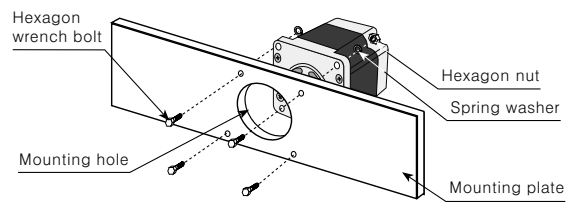

Model	The thickness of mounting plate	Using bolt	Model	The thickness of mounting plate	Using bolt
A□K-□52 □□-□ Series	Min. 3[mm]	M2.6	A□K-□56 □□-□ Series	Min. 4[mm]	M4
A□K-□54 □□-□ Series		M3	A□K-□59 □□-□ Series		Min. 5[mm]

### 2. Connection with load

- ① Please use flexible coupling when assembling a load (Ball-Screw etc.) at the shaft of motor.  
If the center is not matched, it may cause the life cycle of the bearing to be reduced or an incident such as a break of the motor shaft may occurred.

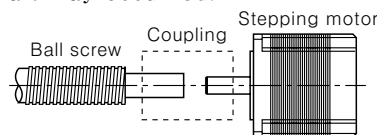

- ② When processing shaft or assembling pulley etc., please don't affect an impact or the weight of thrust to the shaft.

## ■ Caution for using

1. Do not disassemble motor.
2. Do not drop motor.
3. Do not pull the connecting cable of motor.
4. Please avoid the following
  - ① A place which can cause vibration or an impact to motor.
  - ② A place which has a lot of pollutant like dust etc.
  - ③ A place which can cause water or oil etc. to go into motor.
  - ④ A place where flammable or corrosive gas exists.
  - ⑤ A place where the ambient temperature is beyond  $-10^{\circ}\text{C}$  to  $+50^{\circ}\text{C}$ .
5. Temperature rise  
Please use it on a surface temperature under  $100^{\circ}\text{C}$ .  
The surface temperature of motor can be significantly increased in case of driving the motor by constant current. In this case please consider using forced cooling methods like a fan etc.
6. Usage in low temperature  
The features of max. operation and max. start-stop frequency may go down as the ambient temperature of ball bearing for the axis of motor falls down.  
But, use it operating motor slowly as the torque of motor is not damaged.

(A)  
Counter

(B)  
Timer

(C)  
Temp.  
controller

(D)  
Power  
controller

(E)  
Panel  
meter

(F)  
Tacho/  
Speed/  
Pulse  
meter

(G)  
Display  
unit

(H)  
Sensor  
controller

(I)  
Proximity  
sensor

(J)  
Photo  
electric  
sensor

(K)  
Pressure  
sensor

(L)  
Rotary  
encoder

(M)  
5-Phase  
stepping  
motor &  
Driver &  
Controller

# 5-Phase Hollow Type Stepping Motor

## □42mm/□60mm/□85mm Square Series 0.72° 5-Phase Hollow Type Stepping Motor

### ■ Features

- It adopts the method without coupling by assembling directly Ball-screw or TM-screw etc.
- No coupling, low vibration, low noise.
- Economical price.
- Best suited for applications with small sized equipment.
- Compact design and light weight with high accuracy, speed and torque.

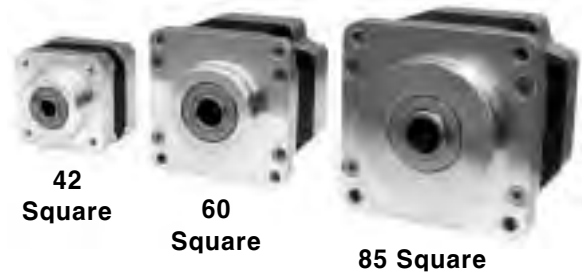

**⚠ Please read "Caution for your safety" in operation manual before using.**



### ■ Dimensions

#### ● AH1K-S543

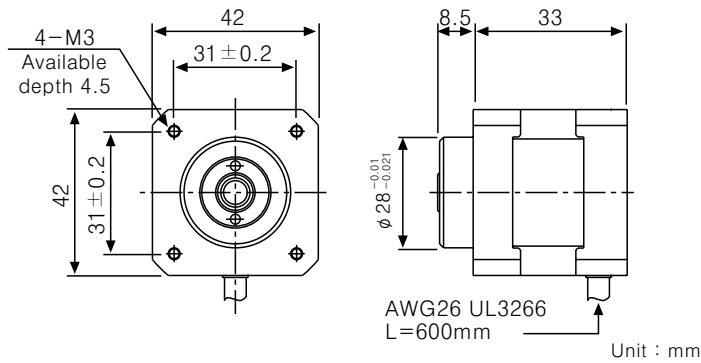

#### ● AH2K-S544

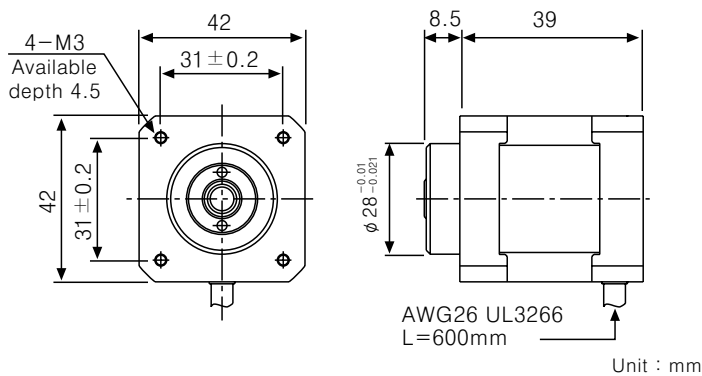

#### ● AH3K-S545

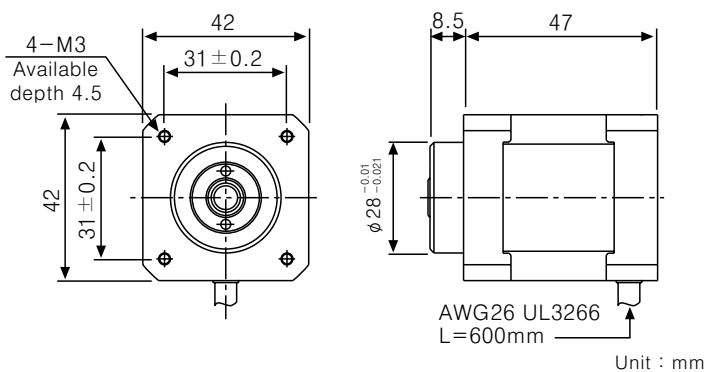

### ■ Characteristic

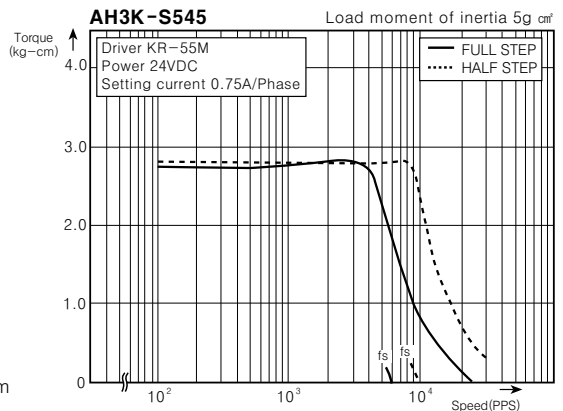
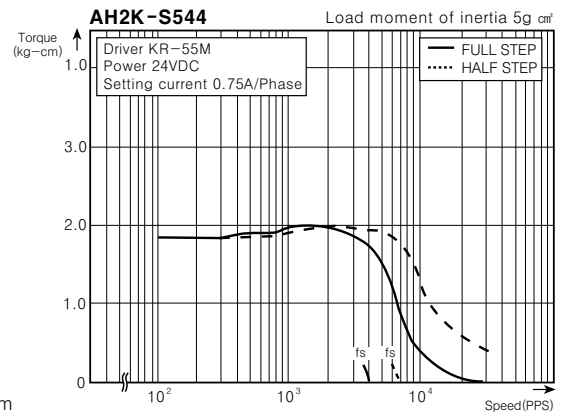
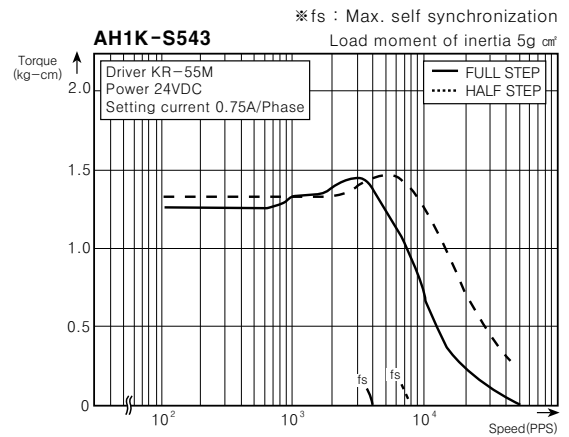

## ■ Dimensions

### ● AH4K - □564(W)

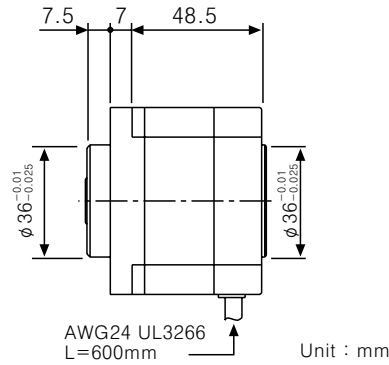
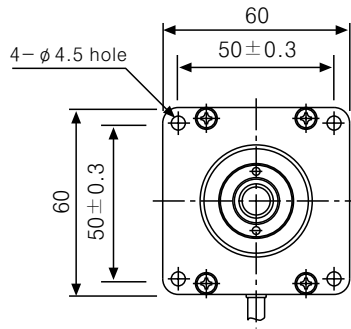

### ● AH8K - □566(W)

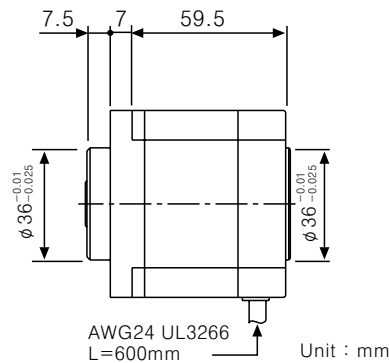
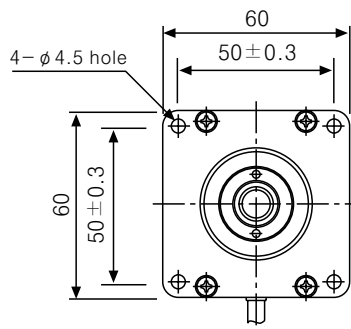

### ● AH16K - □569(W)

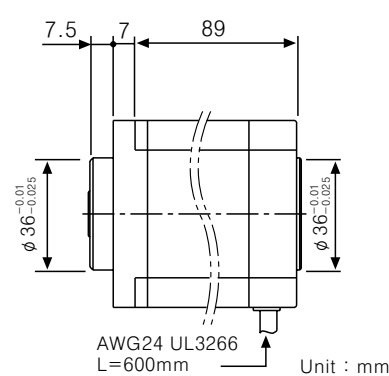
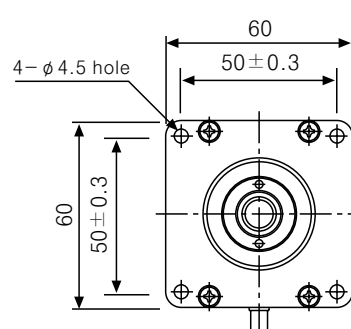

### ● AH21K - □596(W)

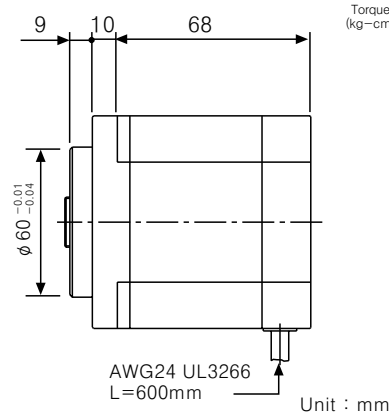
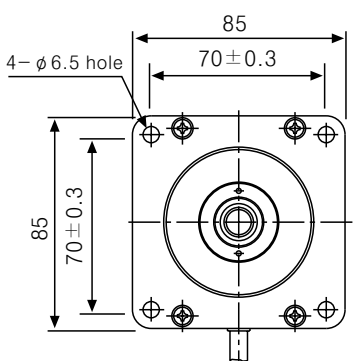

## ■ Characteristic

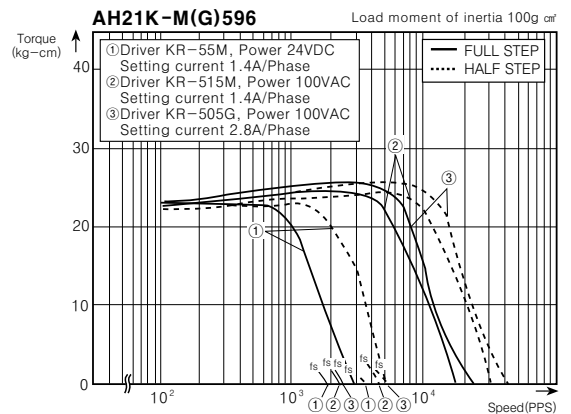
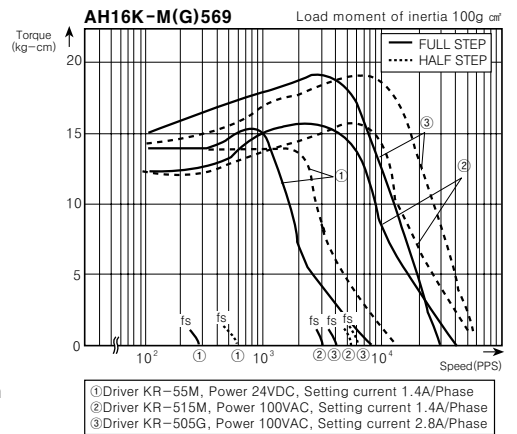
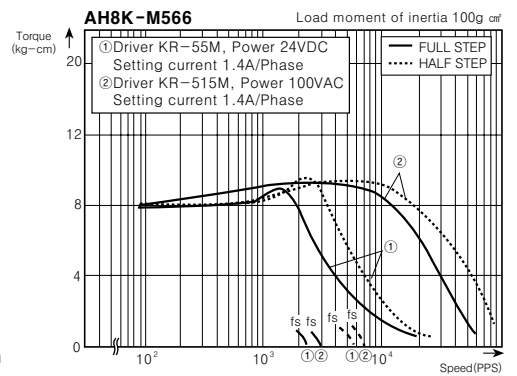
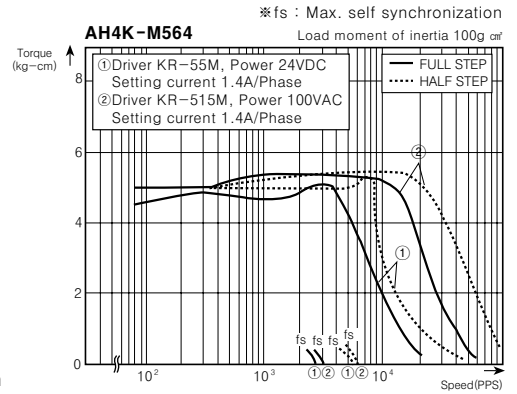

(A) Counter

(B) Timer

(C) Temp. controller

(D) Power controller

(E) Panel meter

(F) Tacho/Speed/Pulse meter

(G) Display unit

(H) Sensor controller

(I) Proximity sensor

(J) Photo electric sensor

(K) Pressure sensor

(L) Rotary encoder

(M) 5-Phase stepping motor & Driver & Controller



# 5-Phase Hollow Type Stepping Motor

## ■ Dimensions

### ●AH41K-□599(W)

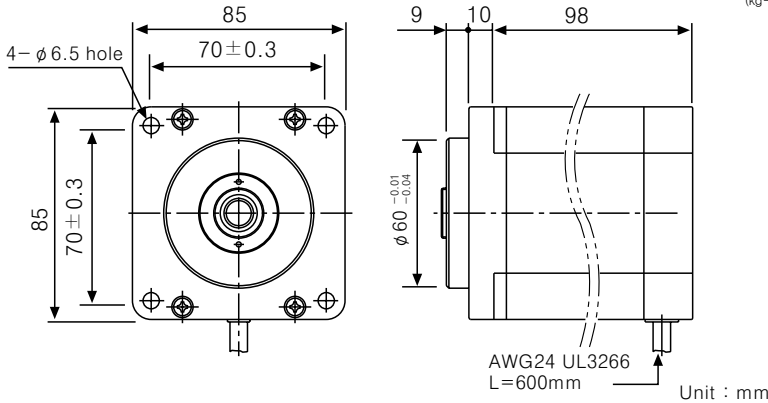

### ●AH63K-□5913(W)

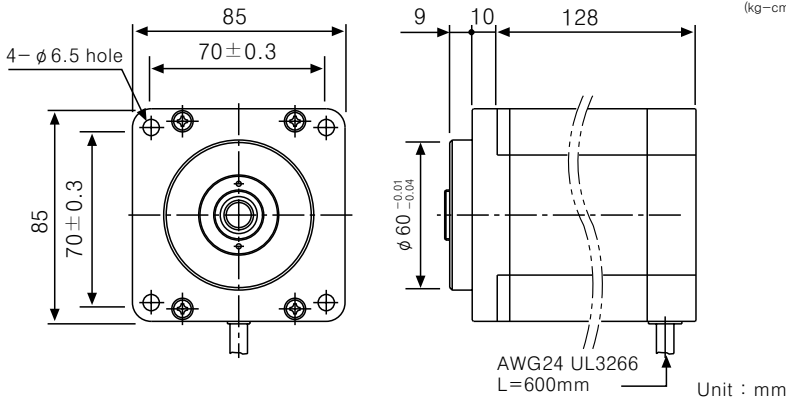

## ■ Characteristic

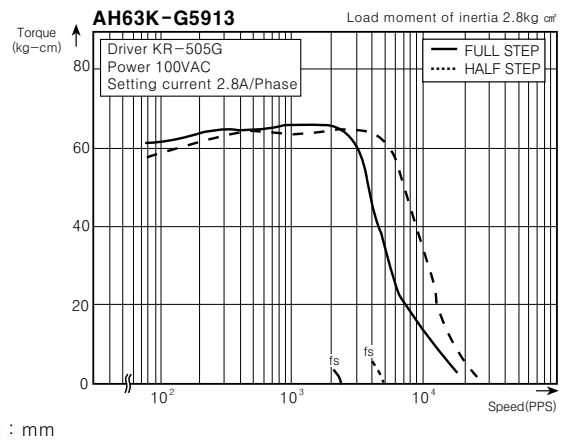
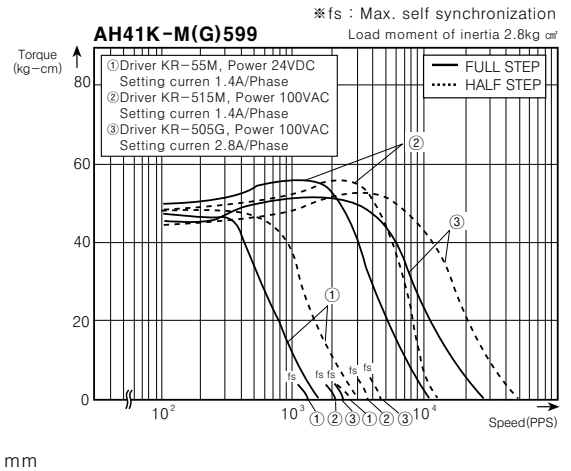

## ■ Connection diagram

Each phase(Coil) of stepping motor and color of lead wire is shown as following.  
Our product has Pentagon and Standard connections by inner connection of motor.

### ●Pentagon connection

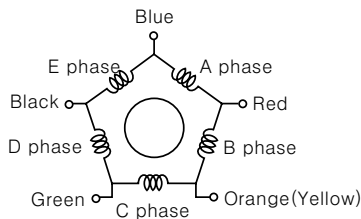

### ●Standard connection

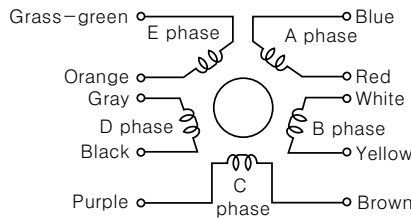

## ■ Motor mounting

It is allowable to mount the motor in any direction of horizon, up or down.  
But, please be careful of overhang and thrust load placed on the shaft.

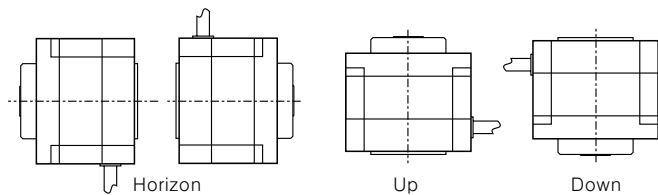

And, be sure of overload on Motor's cable.  
It may cause the cable of Motor to break.

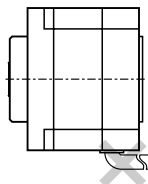

## ■ Shaft processing

In order to connect external shaft to our motor it should be processed as below drawings and be assembled.

### ●42 Square(AH□K-□54□ Series) single shaft

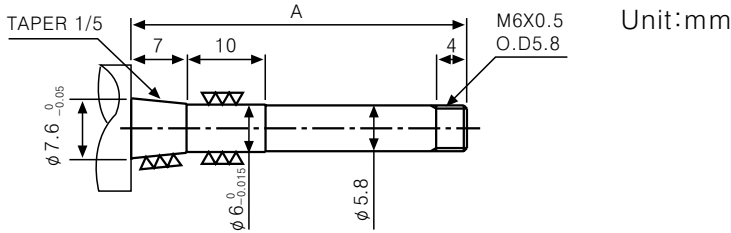

MODEL	A
AH1K-□543	42.5
AH2K-□544	48.5
AH3K-□545	56.5

### ●42 Square(AH□K-□54□ Series) dual shaft

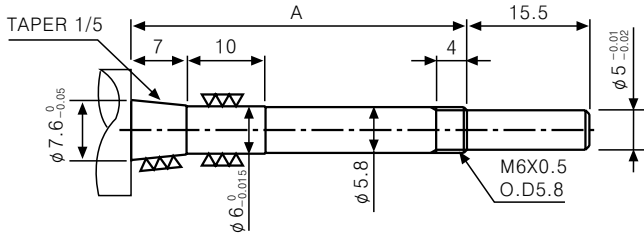

MODEL	A
AH1K-□543	42.5
AH2K-□544	48.5
AH3K-□545	56.5

### ●60 Square(AH□K-□56□ Series) single shaft

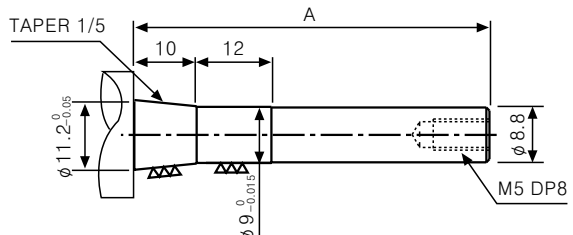

MODEL	A
AH4K-□564	46
AH8K-□566	57
AH16K-□569	86.5

### ●60 Square(AH□K-□56□W Series) dual shaft

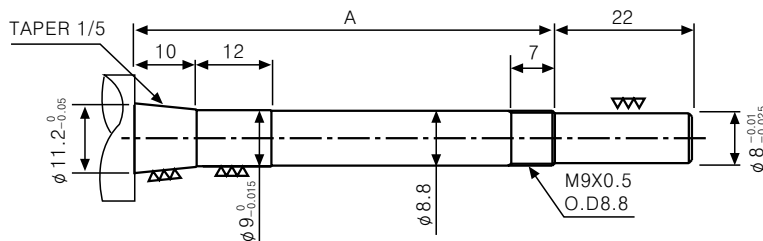

MODEL	A
AH4K-□564W	56.5
AH8K-□566W	67.5
AH16K-□569W	97

### ●85 Square(AH□K-□59□ Series) single shaft

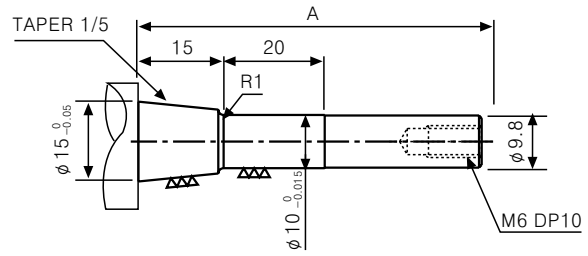

MODEL	A
AH21K-□596	64.5
AH41K-□599	94
AH63K-□5913	124.5

### ●85 Square(AH□K-□59□W Series) dual shaft

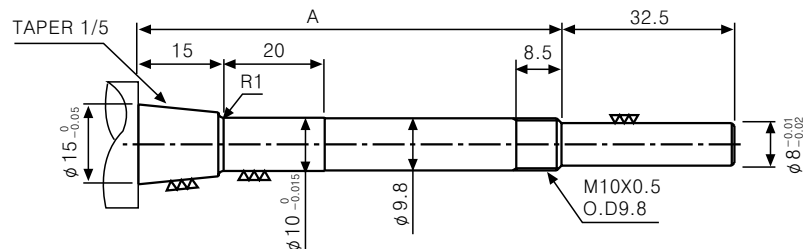

MODEL	A
AH21K-□596W	79.5
AH41K-□599W	109.5
AH63K-□5913W	139.5

(A)  
Counter

(B)  
Timer

(C)  
Temp.  
controller

(D)  
Power  
controller

(E)  
Panel  
meter

(F)  
Tacho/  
Speed/  
Pulse  
meter

(G)  
Display  
unit

(H)  
Sensor  
controller

(I)  
Proximity  
sensor

(J)  
Photo  
electric  
sensor

(K)  
Pressure  
sensor

(L)  
Rotary  
encoder

(M)  
5-Phase  
stepping  
motor &  
Driver &  
Controller

# 5-Phase Hollow Type Stepping Motor

## ■ Shaft for assembly with Motor

Please assemble the shaft with motor tightly as in the following picture. It may be not transferred the torque of motor to the shaft when it is not assembled tightly.

### ●TAP hole type motor

Please use it by fixing lock nut tightly on motor.

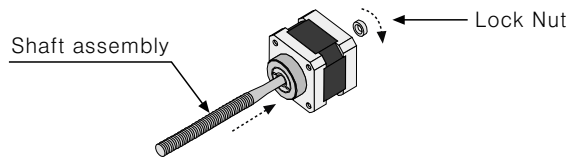

### ●Through hole type motor for single shift

Please use it by fixing hexagon wrench bolt, flat washer, spring washer, lock washer on motor tightly as following drawing.

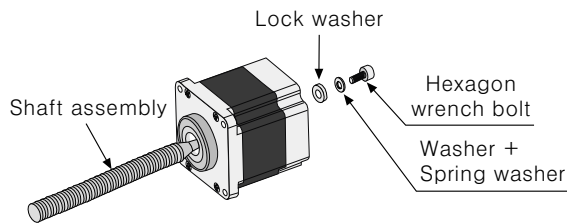

### ●Through hole type motor for dual shift

Please use it by fixing lock nut tightly on motor as in following drawing.

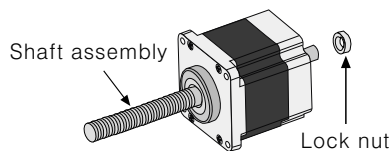

●Please use it by fixing hexagon wrench bolt, nut, spring washer, flat washer on motor tightly when installing motor and refer to the following table for thickness of mounting plate and the bolts.

### < Through hole type >

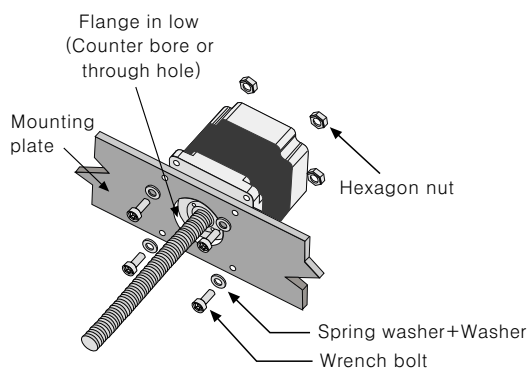

### < Tap hole type >

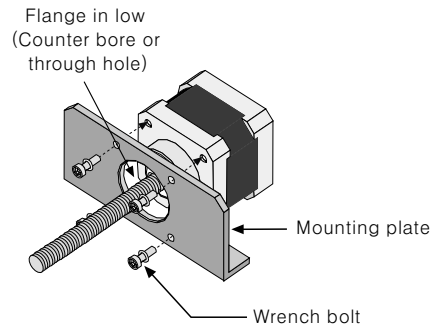

MODEL	The thickness of mounting plate	Using bolt
AH□K-□54□Series	Min. 3[mm]	M3
AH□K-□56□Series	Min. 4[mm]	M4
AH□K-□59□Series	Min. 5[mm]	M6

## ■Caution for using

1. Do not disassemble motor.
2. Do not pull the connecting cable of motor.
3. Please avoid the following
  - ①A place which can cause vibration or an impact to motor.
  - ②A place which has a lot of pollutant like dust etc.
  - ③A place which can cause water or oil etc. to go into motor.
  - ④A place where flammable or corrosive gas exists.
  - ⑤A place where the ambient temperature is beyond of  $-10^{\circ}\text{C} \sim +50^{\circ}\text{C}$ .
5. Temperature rise
 

Please use it on a surface temperature under  $100^{\circ}\text{C}$ . The surface temperature of motor can be significantly increased in case of driving the motor by constant current. In this case please consider using forced cooling methods like a fan etc.
6. Usage in low temperature
 

The features of max operation and max start-stop frequency may go down as the ambient temperature of ball bearing for the axis of motor falls down. But, use it operating motor slowly as the torque of motor is not damaged.

## Ordering information

**A G 40K - M 5 6 6 □ - 7.2 □**

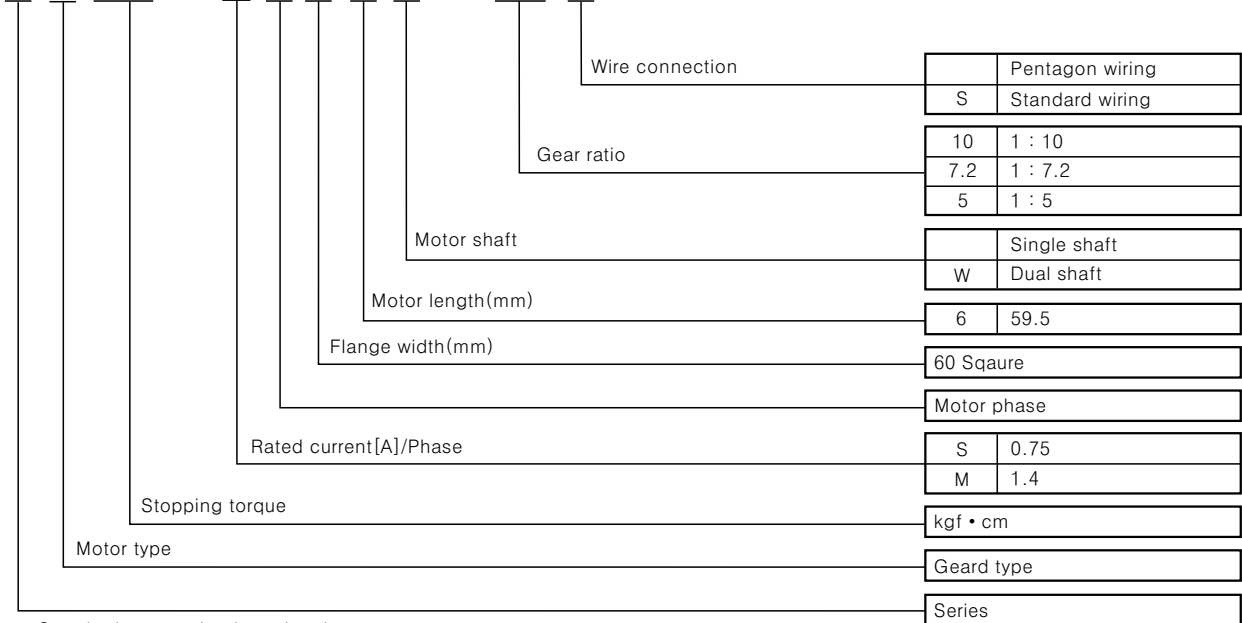

※ Standard connection is optional.  
 ※ Gear ratio 1:5, 1:10 type is coming soon.

## Specifications

Type	Model	Descended rate	Rated current (A/phase)	Max. excitation stop torque(kgf • cm)	Basic step square ( ° )	Allowable torque (kgf • cm)	Backlash (mm)	Allowable speed range(mm)
60 Square	AG35K-S566(W)-5	1:5	0.75	35	0.144	35	20 (0.33°)	0 ~ 360
	AG40K-S566(W)-7.2	1:7.2		40	0.1	40		0 ~ 250
	AG50K-S566(W)-10	1:10		50	0.072	50		0 ~ 180
	AG35K-M566(W)-5	1:5	1.4	35	0.144	35		0 ~ 360
	AG40K-M566(W)-7.2	1:7.2		40	0.1	40		0 ~ 250
	AG50K-M566(W)-10	1:10		50	0.072	50		0 ~ 180

※ ( ) indicates dual shaft of motor.

## Characteristic

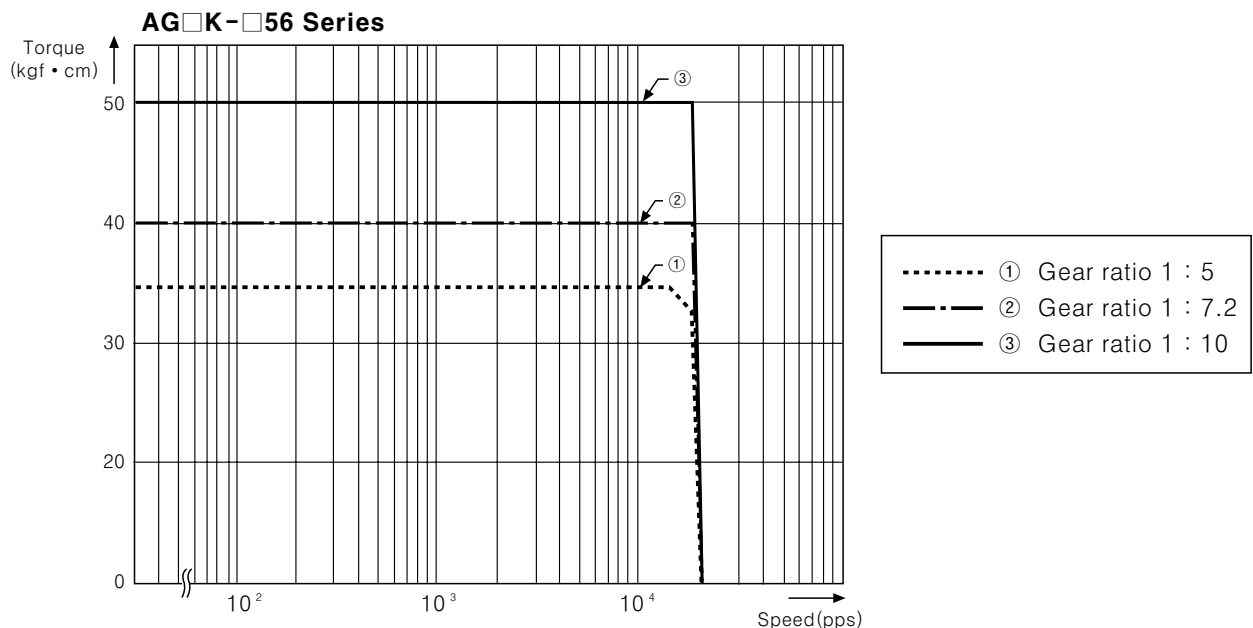

(A) Counter

(B) Timer

(C) Temp. controller

(D) Power controller

(E) Panel meter

(F) Tacho/Speed/Pulse meter

(G) Display unit

(H) Sensor controller

(I) Proximity sensor

(J) Photo electric sensor

(K) Pressure sensor

(L) Rotary encoder

(M) 5-Phase stepping motor & Driver & Controller

# Geared type 5-Phase stepping motor

## ■ Dimensions

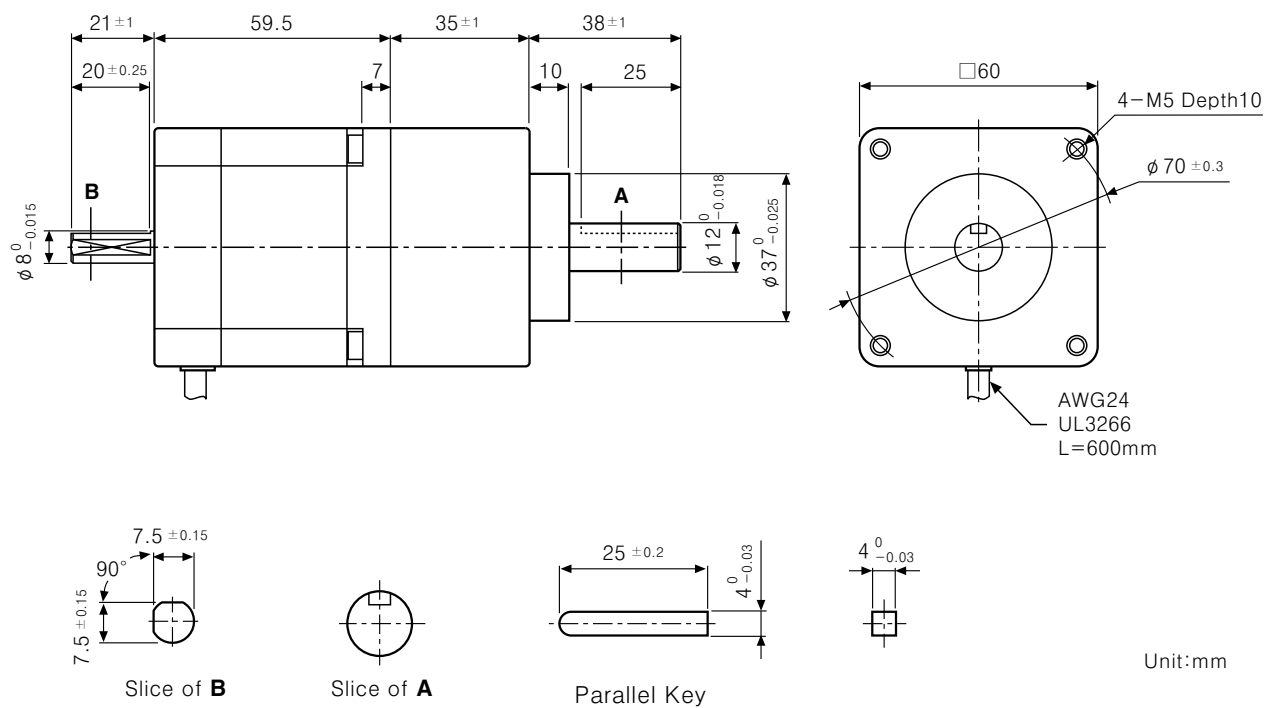

Unit:mm

※The dimension is for dual shaft, otherwise there is no shaft of slice B.

# SPEC SELECTION

## ■ Selection table for stepping motor and driver specifications

(○ : General specification, ◎ : High-torque specification)

Motors				Driver			
Type	Model number	Torque (kgf · cm)	A/phase (A)	KR-5MC KR-5M	KR-55MC (Microstep)	KR-515M (Microstep)	KR-505G
24mm Square	<b>02K-S523(W)</b>	0.18	0.75	○	○	◎	
	<b>04K-S525(W)</b>	0.28	0.75	○	○	◎	
42mm Square	<b>A1K-S543(W)-□</b>	1.3	0.75	○	○	◎	
	<b>A2K-S544(W)-□</b>	1.8	0.75	○	○	◎	
	<b>A3K-S545(W)-□</b>	2.4	0.75	○	○	◎	
	<b>AH1K-S543</b>	1.3	0.75	○	○	◎	
	<b>AH2K-S544</b>	1.8	0.75	○	○	◎	
	<b>AH3K-S545</b>	2.4	0.75	○	○	◎	
60mm Square	<b>A4K-S564(W)-□</b>	4.2	0.75	○	○	◎	
	<b>A4K-M564(W)-□</b>	4.2	1.4	○	○	◎	
	<b>A8K-S566(W)-□</b>	8.3	0.75	○	○	◎	
	<b>A8K-M566(W)-□</b>	8.3	1.4	○	○	◎	
	<b>A16K-M569(W)-□</b>	16.6	1.4	○	○	◎	
	<b>A16K-G569(W)-□</b>	16.6	2.8				◎
	<b>AH4K-S564(W)</b>	4.2	0.75	○	○	◎	
	<b>AH4K-M564(W)</b>	4.2	1.4	○	○	◎	
	<b>AH8K-S566(W)</b>	8.3	0.75	○	○	◎	
	<b>AH8K-M566(W)</b>	8.3	1.4	○	○	◎	
	<b>AH16K-M569(W)</b>	16.6	1.4	○	○	◎	
	<b>AH16K-G569(W)</b>	16.6	2.8				◎
85mm Square	<b>A21K-M596(W)-□</b>	21	1.4	○	○	◎	
	<b>A21K-G596(W)-□</b>	21	2.8				◎
	<b>A41K-M599(W)-□</b>	41	1.4	○	○	◎	
	<b>A41K-G599(W)-□</b>	41	2.8				◎
	<b>A63K-M5913(W)-□</b>	63	1.4	○	○	◎	
	<b>A63K-G5913(W)-□</b>	63	2.8				◎
	<b>AH21K-M596(W)</b>	21	1.4	○	○	◎	
	<b>AH21K-G596(W)</b>	21	2.8				◎
	<b>AH41K-M599(W)</b>	41	1.4	○	○	◎	
	<b>AH41K-G599(W)</b>	41	2.8				◎
	<b>AH63K-M5913(W)</b>	63	1.4	○	○	◎	
	<b>AH63K-G5913(W)</b>	63	2.8				◎

※ ( ) indicates dual shaft of motor.

※ The motor shows a big difference in torque by the characteristics of the driver.

Please refer to the graph in this catalogue that shows the characteristics of motors and drivers.

With KR-5M and KR-55M, the high-speed region torque characteristics are better at 40V than at 24V.

In addition, KR-515M and KR-505G show further improved torque characteristics in the high-speed region.

(A)  
Counter

(B)  
Timer

(C)  
Temp.  
controller

(D)  
Power  
controller

(E)  
Panel  
meter

(F)  
Tacho/  
Speed/  
Pulse  
meter

(G)  
Display  
unit

(H)  
Sensor  
controller

(I)  
Proximity  
sensor

(J)  
Photo  
electric  
sensor

(K)  
Pressure  
sensor

(L)  
Rotary  
encoder

(M)  
5-Phase  
stepping  
motor &  
Driver &  
Controller